



AL-7207/8/9

Quad Ku-Band & Dual C-Band Maritime Stabilized TVRO DUAL System



Installation and Operation Manual

Document: MAN32-0192

Revision: A

COMMUNICATION WITHOUT BOUNDARIES

Orbit Communication Ltd. 8D Hatzoran St. P.O.B. 8657, Netanya 42504, Israel, Tel: +(972) 9 892 2777, Fax: +(972) 9 885 5944 www.orbit-cs.com



Copyright

© 2011 Orbit Communication Ltd. All rights reserved.

All product names are trademarks of Orbit Communication Ltd.

Other names are the property of the respective owners.

No part of this publication may be reproduced, transmitted, transcribed, stored in a retrieval system, or translated into any language or computer language, in any form or by any means, electronic or otherwise, without the prior written permission of Orbit Communication Ltd.

Disclaimer of Warranty

Orbit Communication Ltd has made every effort to ensure the accuracy and relevancy of the material in this document. It is expected that all sections of this document will be read thoroughly and that all information and procedures should be fully understood.

However, Orbit Communication Ltd assumes no responsibility for any errors that may appear in this document, and reserves the right to make changes to the document without notice.

Orbit Communication Ltd makes no warranty of any kind in regard to this document, including, but not limited to, the implied warranties of merchantability and fitness for a particular purpose.

Orbit Communication Ltd disclaims any responsibility for incidental or consequential damages in connection with the furnishing, performance or use of this document.

Parts of this document may be based on hardware or software developed by third-party vendors. Orbit Communication Ltd disclaims any responsibility for the accuracy of this document with respect to such hardware and software, and assumes no responsibility for incidental or consequential damages arising due to discrepancies between this document and such hardware or software.



Revision History

Revision #	Date	Description
Rev: -	July 2010	Initial version
Rev: A	February 2012	Updated version



Table of Contents

SAFETY PRECAUTIONS	- 7 -
ACRONYMS AND ABBREVIATIONS	- 8 -
ABOUT THIS MANUAL.....	- 9 -
1 DUAL SYSTEM	- 10 -
1.1 DESCRIPTION	- 10 -
1.1.1 Dual System Configuration.....	- 10 -
1.1.2 Dual-Antenna Hand-Over Concept	- 12 -
1.1.3 Mapping the Obstruction Zones.....	- 14 -
1.1.4 Hand-Over/Switching Logic	- 14 -
1.2 Theory of Operation - Block Diagram Description.....	- 15 -
2 CCU INSTALLATION AND CONNECTIONS	- 16 -
2.1 CCU INSTALLATION.....	- 16 -
2.2 CONNECTING CCU CABLES	- 18 -
2.2.1 CCU Rear-Panel Connectors Overview	- 18 -
2.2.2 Table 1 - CCU Rear Panel Connectors.....	- 18 -
2.2.3 Table 2 - CCU Rear Panel Connectors.....	- 20 -
2.2.4 General-Purpose Connections (Power, LAN, USB, KB, Mouse)	- 21 -
2.2.5 ADE-BDE LAN Cables Connection	- 22 -
2.2.6 ADE-BDE Fiber Optic Cables Connection (Option)	- 23 -
2.2.7 IF Switch Connection.....	- 24 -
2.3 CONNECTING THE HIGH-SPEED IF SATCOM SWITCH.....	- 24 -
3 DUAL SYSTEM OPERATION.....	- 26 -
3.1 INTRODUCTION	- 26 -
3.2 CCU OPERATION PRINCIPLES.....	- 26 -
3.3 GETTING STARTED - CCU APPLICATION WINDOWS	- 27 -
3.4 DUAL ANTENNA OPERATION SCREEN.....	- 29 -
3.4.1 Introduction.....	- 29 -
3.4.2 Antenna 1 / 2 Monitoring Window	- 30 -
3.4.3 Menu Bar.....	- 31 -
3.4.4 Command Buttons Toolbar	- 32 -
3.4.5 Status Bar.....	- 32 -



3.5	Display Configuration Screen	- 32 -
3.5.1	Introduction.....	- 32 -
3.5.2	Using the Display Configuration Screen	- 32 -
3.6	Obstruction (Blocked) Zones Screen	- 34 -
3.6.1	Introduction.....	- 34 -
3.6.2	Using the Obstruction Zone Screen.....	- 34 -
3.6.3	REMOTE BASIC OPERATION SCREENS.....	- 37 -
4	REMOTE DaoLink APPLICATION	- 38 -



List of Figures

Figure 1 - AL-7207/8/9 Dual TVRO System – Block Diagram.....	- 11 -
Figure 2 - Antenna's Local Azimuth Angles	- 12 -
Figure 3 - Antenna's Local Elevation Angles	- 13 -
Figure 4 - AL-7207/8/9 - Dual CCU Unit.....	- 16 -
Figure 5 - CCU General View.....	- 17 -
Figure 6 - CCU Rear Panel Connectors (with LAN).....	- 18 -
Figure 7 - CCU Rear Panel – General Purpose Connections.....	- 21 -
Figure 8 - CCU Rear Panel – Hub LAN Connectors.....	- 22 -
Figure 9 - CCU Rear Panel – Fiber Optic Connectors	- 23 -
Figure 10 - CCU Rear Panel – Switch Connectors	- 24 -
Figure 11 - IF Switch Connectors (Front and Rear Panels)	- 24 -
Figure 12 - CCU Front Panel.....	- 27 -
Figure 13 - Dual System Operation Screen.....	- 27 -
Figure 14 - Dual System Operation Screen.....	- 29 -
Figure 15 - Antenna Monitoring Window	- 30 -
Figure 16 - Display Configuration Screen.....	- 33 -
Figure 17 - Dual System Operation Screen – Minimal Display	- 33 -
Figure 18 - Blocked Zones Screen.....	- 35 -
Figure 19 - Dual System - Layout Example	- 36 -
Figure 20 - Obstruction Zones Setting - Example.....	- 37 -

SAFETY PRECAUTIONS



- ◆ Keep clear of the moving Antenna, at all times
 - ◆ The Antenna Pedestal is equipped with high torque motors that develop considerable forces. These forces can be harmful
 - ◆ Equipment contains potentially harmful voltages when connected to the designated power sources. Never remove equipment covers except for maintenance or internal adjustments
 - ◆ Before removing the covers of any unit, verify that the POWER switch is in the OFF position
-



- ◆ Metal parts accessible to the operator are connected to the chassis' ground to prevent shock, and similar hazards. The chassis' ground conductor must not be removed. Ensure the enclosure is at ground potential
 - ◆ Only qualified and trained personnel should perform installation, operation and maintenance of this equipment
 - ◆ Care should be taken when lifting the radome since it acts as a sail during windy conditions. At least two people should handle the Radome during installation
 - ◆ To prevent shock or fire hazard, when sub-units are open or cables are disconnected, do not expose the equipment (with the exception of the Radome) to rain or moisture
 - ◆ Avoid making unauthorized modifications to the circuitry. Any such changes to the system will void the warranty
 - ◆ Do not disconnect cables from the equipment while the system is powered-on
-



- ◆ Interfacing equipment requires the use of high quality connectors and cables
 - ◆ Use only ORBIT authorized parts for repair
-



ACRONYMS AND ABBREVIATIONS

ACU.....	Antenna Control Unit
ADE	Above Deck Equipment
BDE.....	Below Deck Equipment
CCU	Central Control Unit
DTS.....	Direct-To-Sailors
GND.....	Ground
HDD.....	Hard Disk Drive
IMU.....	Inertial Measurement Unit
LAN	Local Area Network
LAT.....	Latitude
LOS	Line of Sight
LHCP	Left Hand Circular Polarization
LONG	Longitude
MMI.....	Man-Machine Interface
RHCP	Right Hand Circular Polarization
TVRO.....	TV Receive Only



ABOUT THIS MANUAL

This Manual provides the shipboard system's operator with system description, and operation instructions. The Manual is divided into the following chapters:

Chapter 1. Dual System Description

Provides a general description of the dual system architecture, system units and theory of operation

Chapter 2. CCU Installation and Connections

Provides CCU installation information, of CCU cables connection instructions

Chapter 3. Dual System Operation

Provides detailed operation information and instructions

Chapter 4. Remote DaoLink Application

Provides short introduction to the 'Remote DaoLink Application'

1 DUAL SYSTEM



This manual is an addition to each of the AL-7207/8 SYSTEM INSTALLATION and OPERATION MANUAL

1.1 DESCRIPTION

1.1.1 Dual System Configuration

To overcome severe visibility angles limitations existing on some ships, dual system configuration is installed on a single ship.

The dual system constellation allows combining the clear view angles of two different locations on a single ship, by switching the Receive (Rx) and Transmit (Tx) signals from a blocked location to a clear one.

The dual system configuration includes two AL-7207/8/9 Systems (ADE terminals only), controlled by a single 'Dual type' Central Control Unit (BDE).

The CCU is connected to the SBC in each of the ADE terminals via LAN cables or F/O.

The L-Band signals from the two terminals are fed into an internal RF Switch inside the CCU, and the CCU controls the IF Tx/Rx signals, and switch simultaneously to connect the Modem to the "active" system, with the optimal (un-obstructed) signal, to the distribution system.

The dual system configuration is shown in the following Figure.

AL-7207/8/9 Quad Ku-Band & Dual C-Band TVRO System

AL-7207/8/9 Quad Ku-Band & Dual C-Band TVRO System

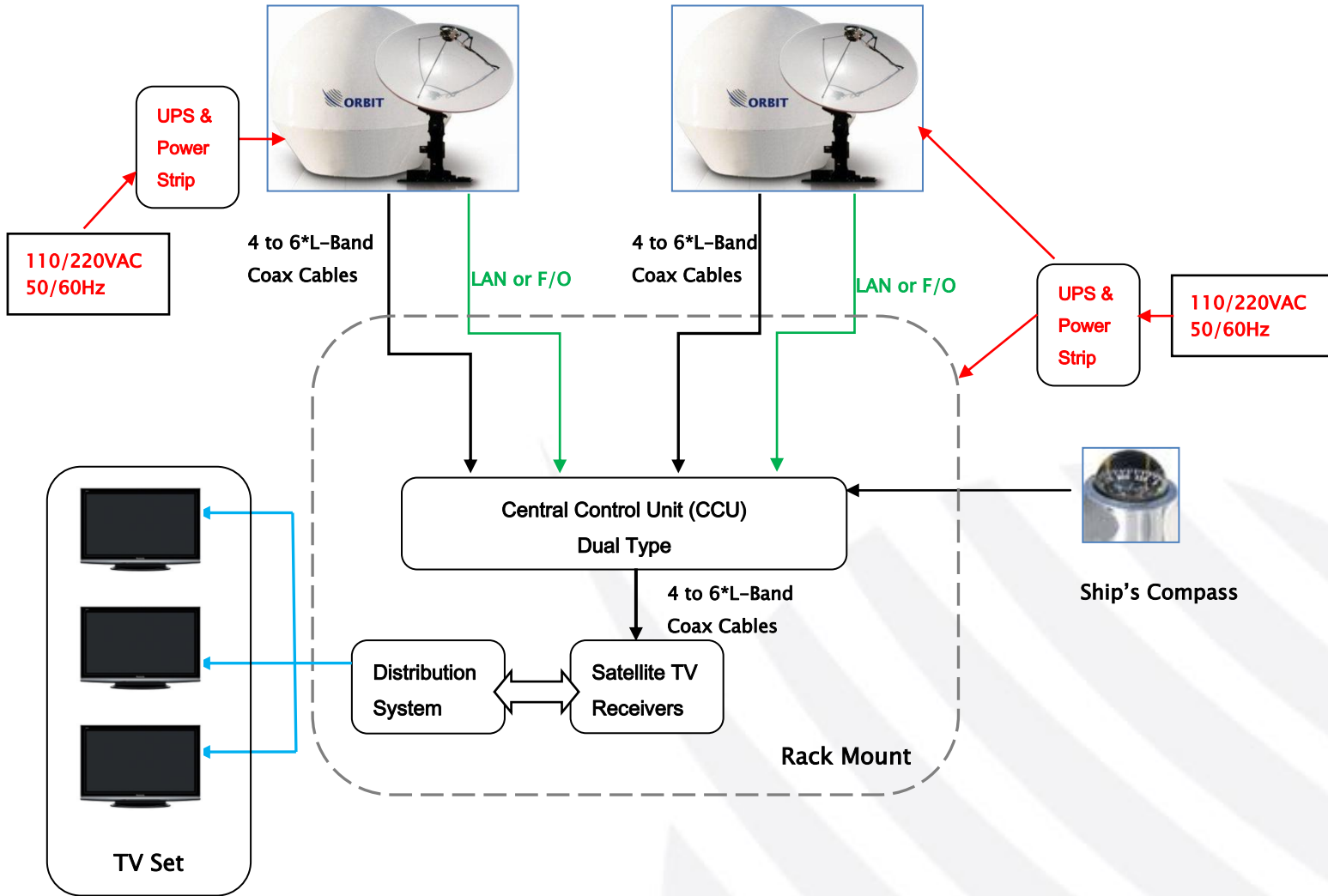

Figure 1 - AL-7207/8/9 Dual TVRO System – Block Diagram



- The power to the system must be supplied through a UPS unit
- The following equipment is not supplied nor supported by Orbit:
TV receivers, distribution systems, TV sets.

1.1.2 Dual-Antenna Hand-Over Concept

This section describes the concept of hand-over between the two antenna systems that are installed on a ship.

Local Antenna Angles

For each antenna system, Local Antenna angles are defined:

- Local Antenna Azimuth
- Local Antenna Elevation

These angles are needed for mapping the obstruction zones on the ship.

The following Figures present the physical definition of the Local Azimuth and Elevation angles.

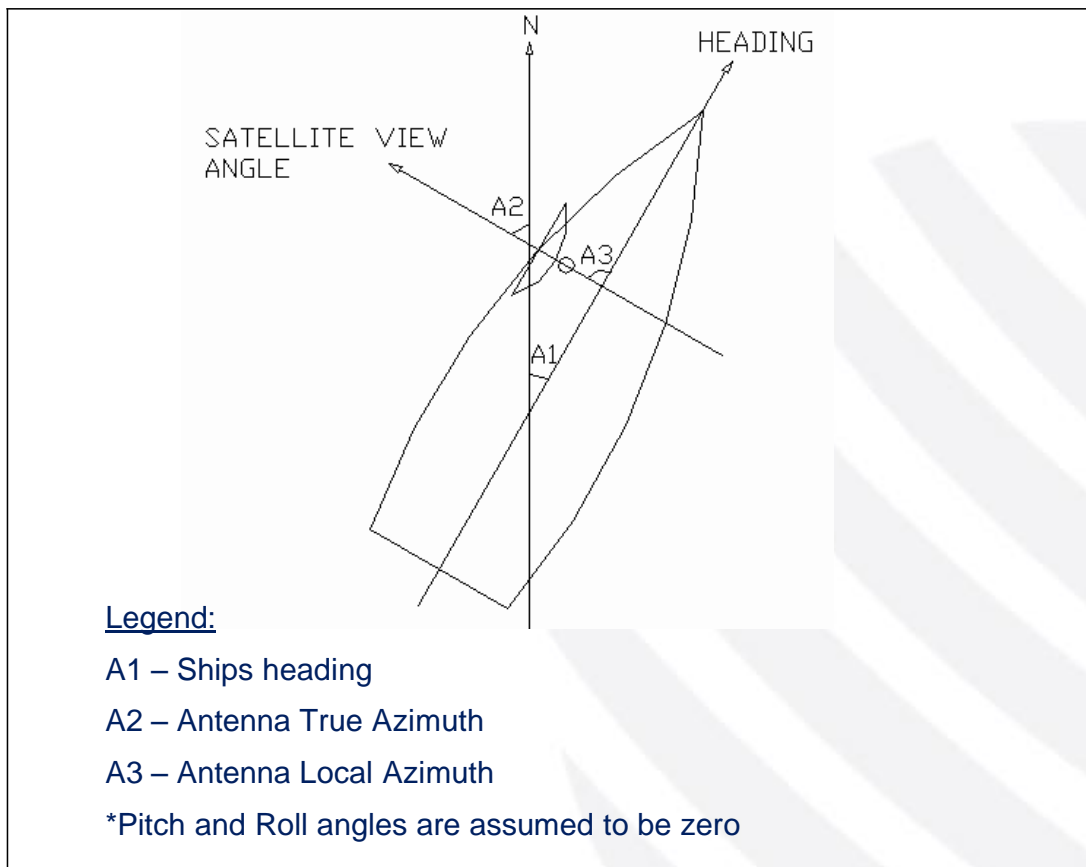

Figure 2 - Antenna's Local Azimuth Angles

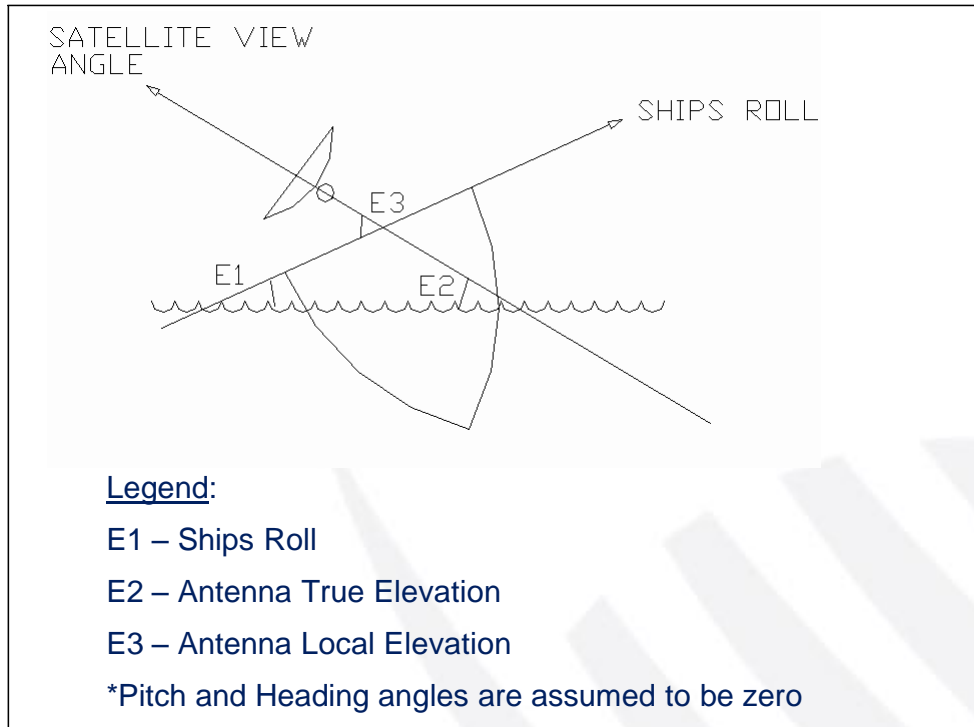

Figure 3 - Antenna's Local Elevation Angles

As shown in the above Figures, it is visible that the Antenna Local Azimuth is the Antenna Azimuth with respect to the ships' Bow-to-Stern line, rather than the North direction, whereas the Antenna Local Elevation is the Antenna Elevation with respect to the ships' deck rather than the horizon level.



The local angles depicted on the figures above are only for illustration. The actual mathematical definition of those angles is a bit more complex and takes into consideration ships Pitch, Roll and Heading at all times.



1.1.3 Mapping the Obstruction Zones

The local angles are used to define and map the antenna obstructions on the ship's deck, by surveying each antenna location and noting the corner angles of each obstruction in Local Azimuth and Elevation terms.

The two-dimensional obstruction definition of each of the two antenna locations is then being entered into the CCU, which in turn will control its internal RF switch, switching the signal coming from the preferable unit.

1.1.4 Hand-Over/Switching Logic

The CCU continuously monitors the Local Azimuth and Elevation of both antennas, and switches the RF signals from the two antennas using the following switching logic:

- If Antenna 1 is clear, and Antenna 2 is blocked, Antenna 1 signal is selected
- If Antenna 2 is clear, and Antenna 1 is blocked, Antenna 2 signal is selected
- If both antennas are clear, no switching is activated
- If both antennas are blocked, no switching is activated

The above hand-over logic offers two advantages:

1. Natural hysteresis by overlapping zones.
2. Future support for systems with more than two antennas.



1.2 Theory of Operation - Block Diagram Description

The dual-antenna system comprises two AL-7207/8/9 Antenna Systems and a Single 'Dual-type' CCU Central Control Unit (CCU).

The systems' 'Above-Deck-Equipment' (ADE) is installed on the ship's deck, while the CCU is a Below-Deck-Equipment (BDE) that is placed either in an environmentally controlled indoor compartment, or in a control room.

The CCU is connected to both ADE terminals (actually to the SBC within each terminal) via coaxial cables, implementing CCU to SBC LAN connection for monitoring and control (M&C), or via Single-Mode or Multi-mode Fiber Optic cables (with ST connectors), implementing standard Ethernet LAN link featuring the TCP/IP protocol, which provides the following benefits:

- High data rates with hardly noticeable on-screen delay
- Error checking and correction
- Standard, available hardware

The CCU constantly monitors both antenna systems. It calculates their Local Azimuth and Elevation angles while comparing those against a preset Obstruction Zones mask. All that to produce an appropriate control command to the external L-Band RF switch, which in turn will interconnect the ship's modem to the non-obstructed antenna system.

2 CCU INSTALLATION AND CONNECTIONS

2.1 CCU INSTALLATION

The CCU is a 5U height unit, typically installed on a dedicated 19-inch rack, located in a ship's equipment room.

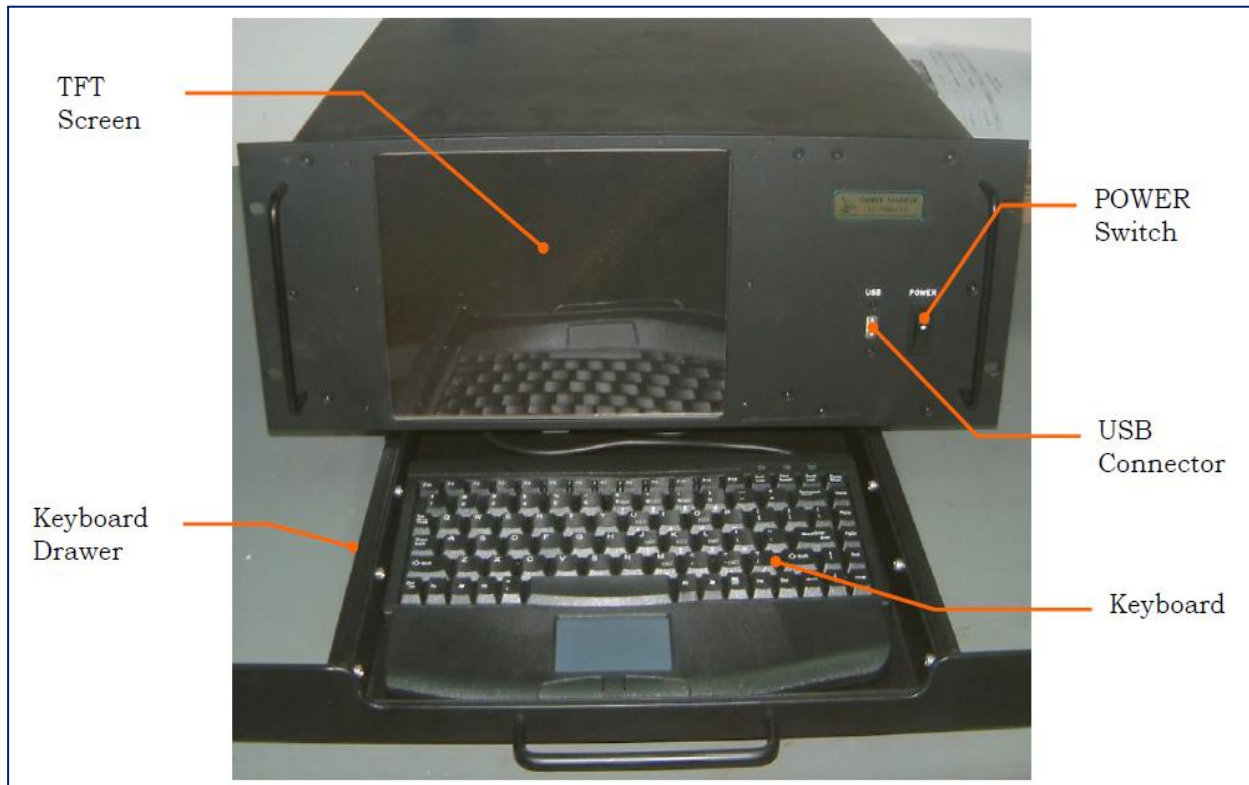

Figure 4 - AL-7207/8/9 - Dual CCU Unit



CCU must be installed at a distance of at least 5 meters from the vessel's compass.

The following Figure depicts the CCU (with the keyboard drawer) external views:

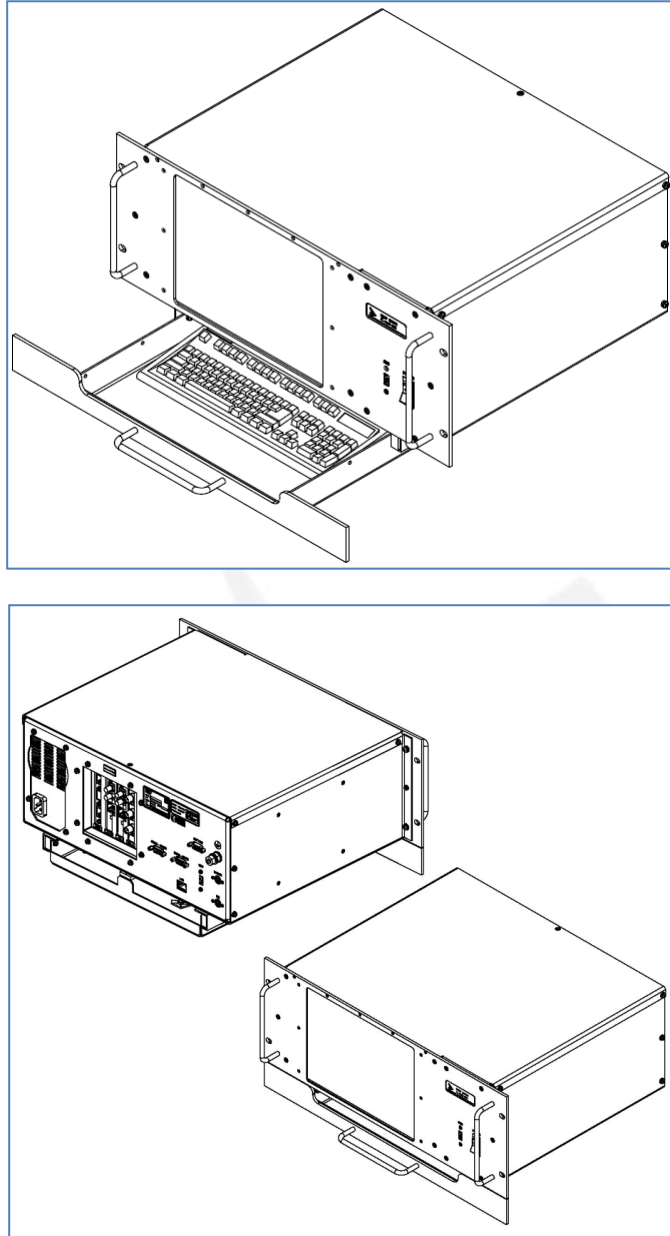

Figure 5 - CCU General View

2.2 CONNECTING CCU CABLES

2.2.1 CCU Rear-Panel Connectors Overview

The following Figure shows the CCU rear-panel connectors, and the subsequent Table specifies the type and function of each connector.



Figure 6 - CCU Rear Panel Connectors (with LAN)

2.2.2 Table 1 - CCU Rear Panel Connectors

Connector	Connector Type	Function
Power Supply Inlet	Integrated plug	Mains power connection (power cord from ship's power source).
COM1	DB9 male	Serial communication connector (RS-422)
COM2	DB9 male	Serial communication connector (RS-232)
CPU Board Connectors		
LAN	RJ-45	Connects to the HUB connector via a jumper cable.
VGA	DB 15-Pin HD	Connects to an external VGA monitor.



KB / MOUSE	MINI-DIN	Connects the CCU to the keyboard located at the CCU drawer.
SW-1 Board Connectors		
N.C.	F-type	Normally Close
OUT	F-type	Out
N.O.	F-type	Normally Open
SW-2 Board Connectors		
N.C.	F-type	Normally Close
OUT	F-type	Out
N.O.	F-type	Normally Open
SW-3 Board Connectors		
N.C.	F-type	Normally Close
OUT	F-type	Out
N.O.	F-type	Normally Open
SW-4 Board Connectors		
N.C.	F-type	Normally Close
OUT	F-type	Out
N.O.	F-type	Normally Open



2.2.3 Table 2 - CCU Rear Panel Connectors

Connector	Connector Type	Function
F/O LAN	RJ-45	Connects to the Hub's F/O 1 LAN Connector via a jumper cable
F/O-2 Board Connectors (for optional configuration)		
F/O TX		CCU – SBC2 fiber optic communication link – transmit line
F/O RCV		CCU – SBC2 fiber optic communication link – receive line
F/O LAN	RJ-45	Connects to the Hub's F/O 2 LAN Connector via a jumper cable
HUB connectors		
F/O 1	RJ-45	LAN port for F/O 1 Board
F/O 2	RJ-45	LAN port for F/O 2 Board
LAN	RJ-45	LAN connector. Connected to the CCU LAN Connector by a jumper cable
	RJ-45	Connects to the BDE-ADE (system 1) cable.
	RJ-45	Connects to the BDE-ADE (system 2) cable.

2.2.4 General-Purpose Connections (Power, LAN, USB, KB, Mouse)

The following Figure depicts the general-purpose cables that should be connected to the CCU:

- ◆ Power cable
- ◆ LAN Jumper cables between the Hub and CCU LAN connector
- ◆ USB Connector
- ◆ Keyboard and Mouse



Figure 7 - CCU Rear Panel – General Purpose Connections

2.2.5 ADE-BDE LAN Cables Connection

Each of the two ADE SBCs is connected to a CCU Hub port by a LAN cable.



HUB LAN
Ports

Figure 8 - CCU Rear Panel – Hub LAN Connectors



Important Note:

The Dual CCU, integrated in AL-7207/8/9 Dual TVRO system, can support only 4 switches for dual function, the other 2 channels (Total there are 6 Channels per system) will be directed to a fixed system - one of them.

In case of F/O connection – there will be less RF switches, due to limit of space and functionality in the Dual CCU design.

2.2.6 ADE-BDE Fiber Optic Cables Connection (Option)

The Dual System configuration implies that each ADE, specifically each of SBCs is connected to the CCU by a Single-Mode or Multi-Mode Fiber Optic cable with two connectors.

- Connect the fiber optic cable coming from SBC 1 to F/O 1 Card connectors RCV and TX.
- Connect the fiber optic cable coming from SBC 2 to F/O 2 Card connectors RCV and TX.

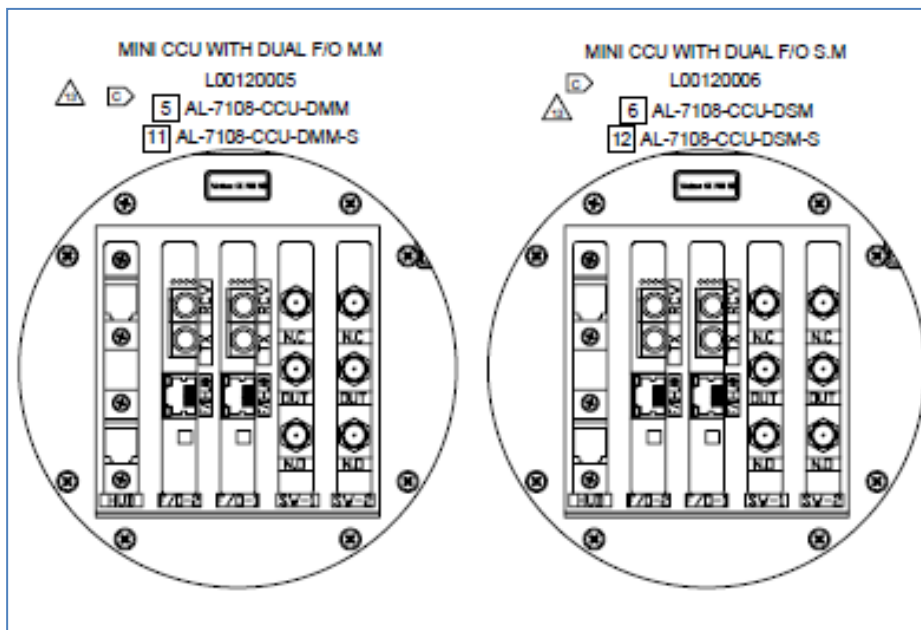

Figure 9 - CCU Rear Panel – Fiber Optic Connectors

2.2.7 IF Switch Connection

The external IF Switch is connected to the CCU via the SW-1/SW-2/SW-3/SW-4 OUT connector.

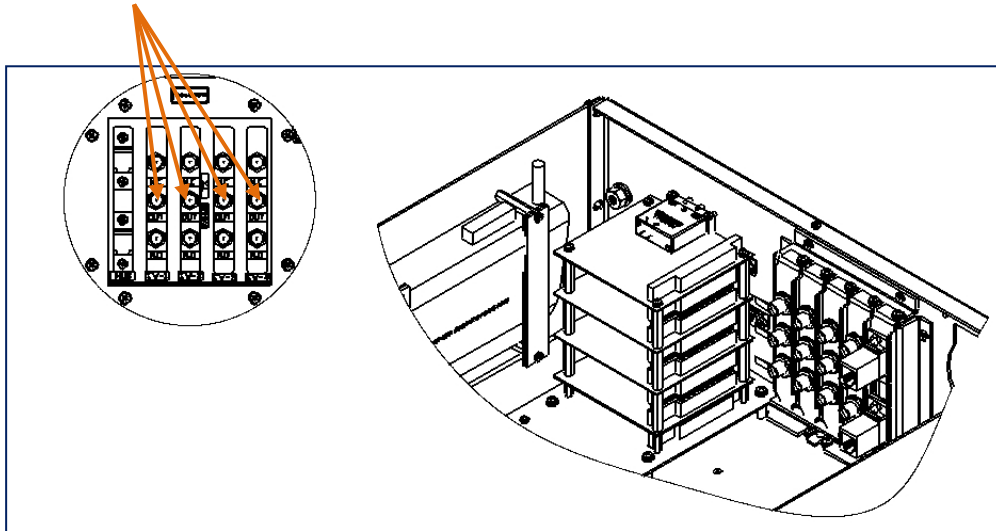

Figure 10 - CCU Rear Panel – Switch Connectors

2.3 CONNECTING THE HIGH-SPEED IF SATCOM SWITCH

The High-speed IF-Switch (19", 2U, rack mountable) is controlled by the CCU, and provides seamless handover for the dual antenna system.



Figure 11 - IF Switch Connectors (Front and Rear Panels)



To connect the IF-Switch to the system, perform the connections listed in the following table.

Table 1 IF Switch Connectors

Function	Connector Number	Connection
POWER		Mains power inlet.
CONTROL	J7	Control cable from SW-2 OUT connector.
SWITCH 1		
N.C.	J2	RF signal received at System 1.
COM	J1	Modem's Rx Input
N.O.	J3	RF signal received at System 2.
SWITCH 2		
N.C.	J5	Transmitted RF signal to System 1.
COM	J4	Modem's Tx output
N.O.	J6	Transmitted RF signal to System 2.



3 DUAL SYSTEM OPERATION

3.1 INTRODUCTION

This section describes the operation procedures of the Dual system, carried out by the system's operator using the CCU.

3.2 CCU OPERATION PRINCIPLES

Operation of the dual system is controlled from the below-deck CCU, which is used to control the system, to monitor system status, and to setup and configure operational parameters.

The CCU is a PC computer running *Windows CE* operating system and several dedicated software applications. These applications control, monitor and configure the dual-antenna system.

The CCU constantly monitors both antenna systems. It calculates their Local Azimuth and Elevation angles while comparing those against a preset Obstruction Zones mask. All that to produce an appropriate control command to the CCU's RF switches, which in turn will connect the signals from the non-obstructed antenna to the ship's Modem.

3.3 GETTING STARTED - CCU APPLICATION WINDOWS

To turn on the CCU, set its POWER switch to the ON position.

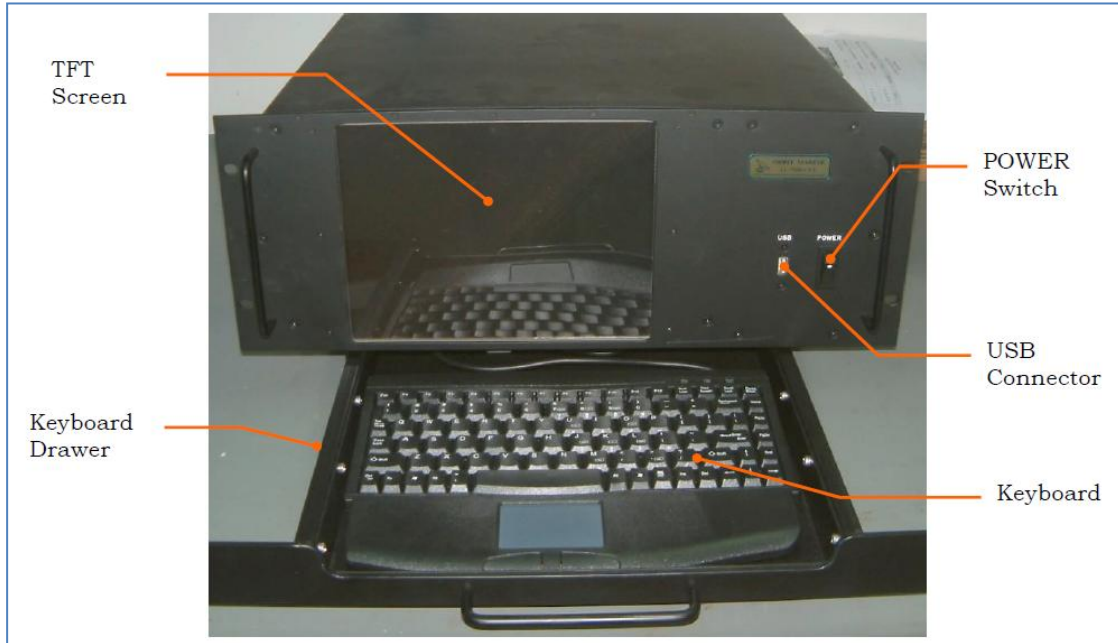

Figure 12 - CCU Front Panel

The CCU invokes the *Windows CE* operating system and automatically opens the following 'Dual Antenna Operation' screen:

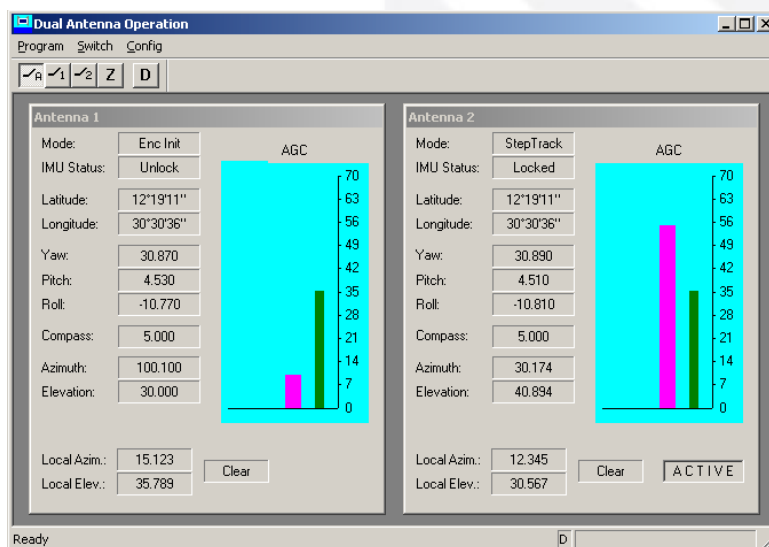
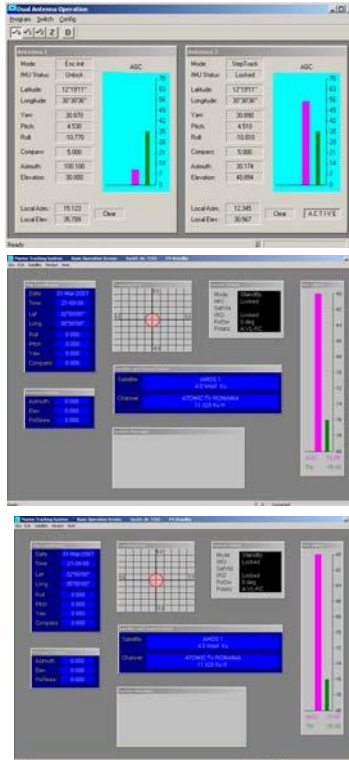

Figure 13 - Dual System Operation Screen



This screen allows access (using windows tabs) to the following windows (Applications):



Dual Antenna Operation:

This window, which is the main application of the CCU, monitors the status of both systems, allows manual or automatic switching of RF signals from the systems' antennas, and enables configuration of obstruction zones.

Marine Tracking System (Antenna 1) – Basic Operation Screen:

This window provides remote monitoring and operation of system #1.

Marine Tracking System (Antenna 2) – Basic Operation Screen:

Same as above for system #2

The following paragraphs describe the above windows and detail the operation procedures available from each window.

3.4 DUAL ANTENNA OPERATION SCREEN

3.4.1 Introduction

The Dual Antenna Operation screen is divided into several display and control zones, as shown in the following Figure:

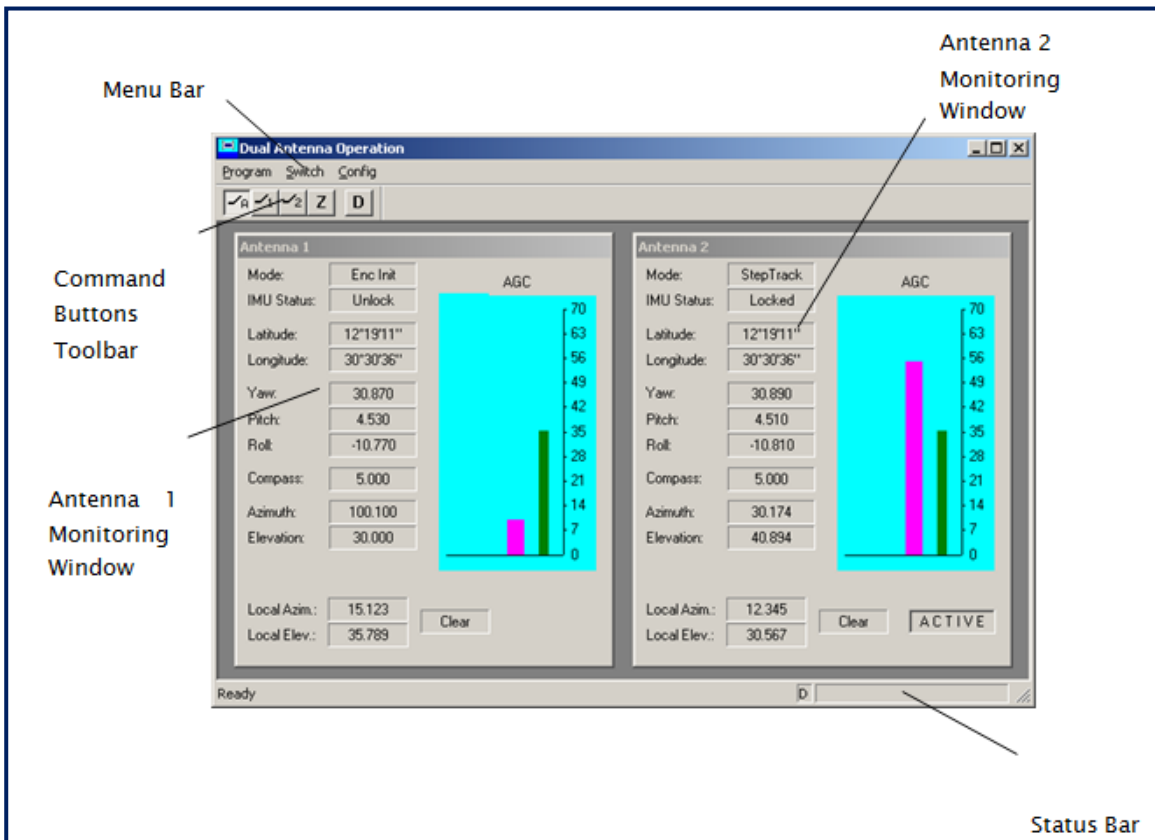

Figure 14 - Dual System Operation Screen

3.4.2 Antenna 1 / 2 Monitoring Window

The Antenna Monitoring window provides remote monitoring of a system, displaying operation modes, parameters and status indications of the system.

A display configuration function is used to determine the fields to be presented on the screen.

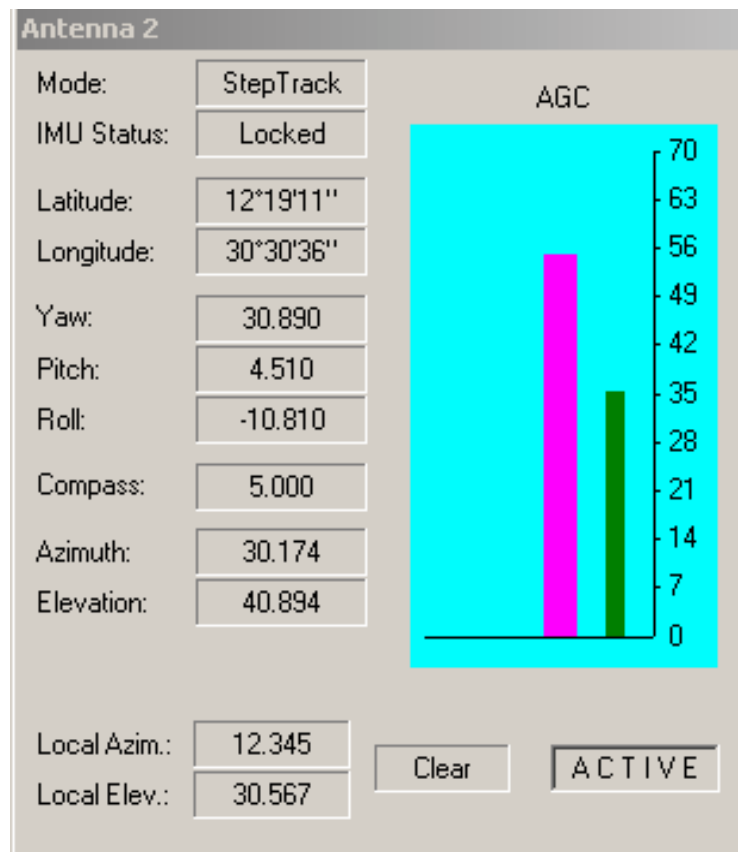

Figure 15 - Antenna Monitoring Window

The window includes the following display fields:

Mode and IMU Status:

- **Mode**- Current system operation mode
- **IMU status**- Current system's IMU status (locked, unlocked)

Ship Position Data:

- **Longitude** - Ship's longitude (from the system's GPS receiver)
- **Latitude** - Ship's latitude (from the system's GPS receiver)
- **Yaw** - Ship's yaw angle (from the system's IMU)
- **Pitch** - Ship's pitch angle (from the system's IMU)
- **Roll** - Ship's roll angle (from the system's IMU)



- **Compass** - Ship's heading (as read from the ship's compass or as entered manually)

Antenna Position Data:

- **Azimuth** - Azimuth axis angle
- **Elev.** - Elevation axis angle

AGC Field:

This field graphically presents the AGC signal level, which represents the strength of the satellite's signal received by the antenna, side-by-side with the Acquire threshold level.

Local Angles Data:

- **Local Azim.** – Local Azimuth angle
- **Local Elev.** - Local Elevation angle
- **Local Azim. Clear/Blocked** - Local Azimuth clear/blocked indicator
- **Local Elev. Clear/Blocked** - Local Elevation clear/blocked indicator

Switching Indicator:

- **ACTIVE** – When the Antenna system's RF signals (Tx and Rx) are switched to the ship's Modem, this indicator appears on the window.

3.4.3 Menu Bar

The Menu Bar provides access to the following functions:

Program Switch Config





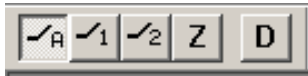

The underlined letters denote the fast activation keys (shortcuts) for the same functions.

- **P**rogram – Displays the following drop-menu:
 - **S**how **V**ersion – Displays the Version window, containing software Versions data
 - **Esc-Exit** – Terminates the application
- **S**witch - Displays a drop-menu which allows to manually switch the RF signals from either Antenna 1 or Antenna 2, or to select Automatic switching.
- **C**onfig – Displays the following drop-menu:
 - **Z**ones – Opens the Blocked Zones window
 - **D**isplay – Opens the Display Configuration window
 - **L**ink – Opens the Link Setup window

3.4.4 Command Buttons Toolbar



-  Selects automatic switching of RF signals from the antenna systems to the ship's Modem. In this mode, the RF switch is controlled by the CCU according to the obstruction zones
-  Manually switches the RF signals from Antenna 1 to the ship's Modem
-  Manually switches the RF signals from Antenna 2 to the ship's Modem
-  Opens the Blocked Zones window
-  Opens the Display Configuration window

3.4.5 Status Bar

The Status Bar displays the current CCU mode:

MODE:MANUAL

MANUAL - RF switch is manually forced to one of the antennas

AUTO - RF switch is controlled by the CCU

3.5 Display Configuration Screen

3.5.1 Introduction

As stated above, the Antenna Monitoring windows display status and operational parameters read from the systems' controllers.

The Display Configuration screen allows selecting or de-selecting the indicators to be displayed on the Antenna Monitoring windows.

3.5.2 Using the Display Configuration Screen

To invoke the Display Configuration screen, select either the menu bar's **C**onfig>**D**isplay option or the **D** command button. The following window is displayed:

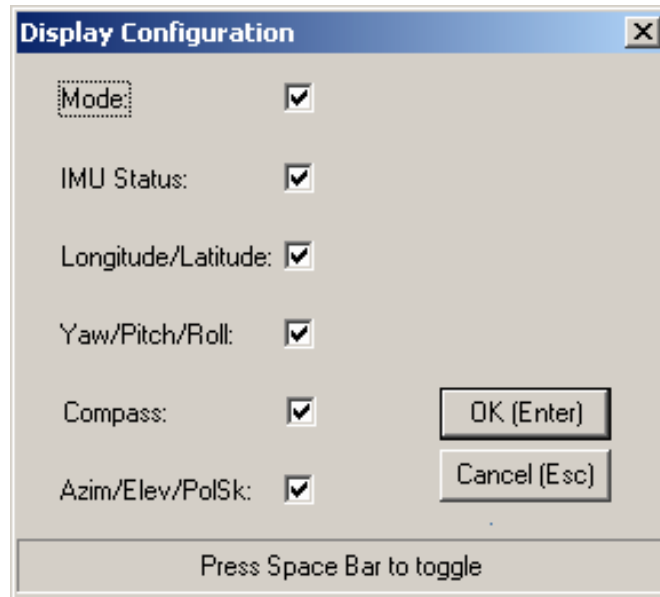

Figure 16 - Display Configuration Screen

Select (by checking - \checkmark) or de-select the pertaining boxes to configure the Antenna Monitoring windows display.

For example, the following Figure shows the Dual Antenna Operation screen with all display fields de-selected (minimal display):

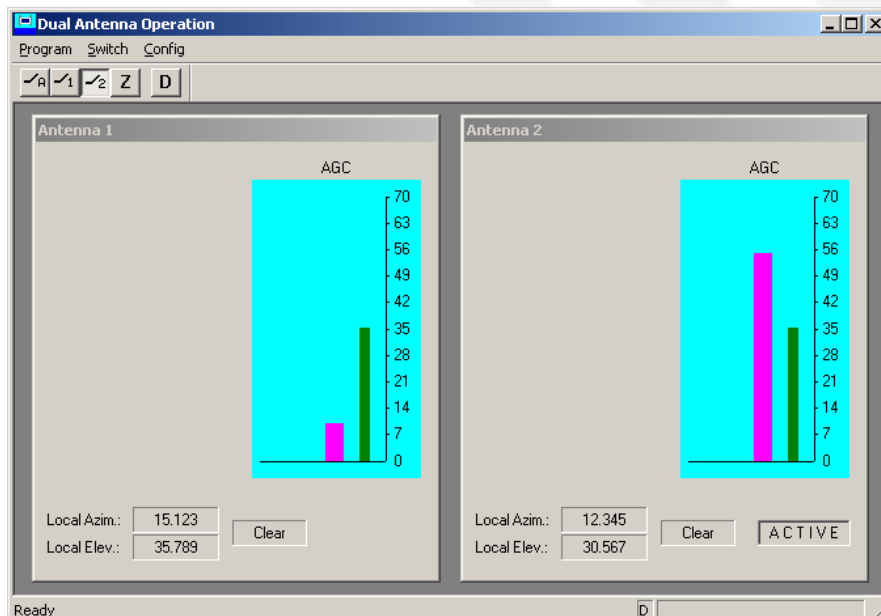

Figure 17 - Dual System Operation Screen – Minimal Display



3.6 Obstruction (Blocked) Zones Screen

3.6.1 Introduction

For each one of the systems, an Obstruction Zone screen allows defining of up to four obstruction zones, at which the antenna line-of-site (LOS) is blocked.

To define an obstruction zone, four angular points (at Local angles values) are entered into the CCU:

- ◆ Azimuth Start (from).
- ◆ Azimuth End (to).
- ◆ Elevation Start (from).
- ◆ Elevation End (to).

It is not mandatory to enter values for all the zones – leaving blanks in the “from” and “to” fields will effectively disable the relevant zone. However, if a zone is to be defined only in Azimuth, the Elevation angles should be set from 0 to +90 degrees.

3.6.2 Using the Obstruction Zone Screen

There are two ways to invoke an Obstruction Zone Screen: Select the menu bar's

Config>Zones option;

-or-

Select the  command button.

The following window is displayed:

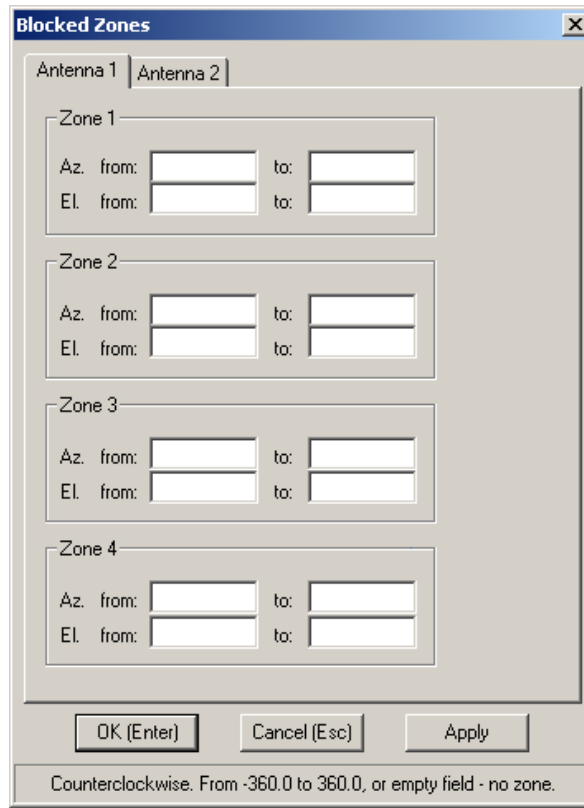

Figure 18 - Blocked Zones Screen

Select the **Antenna 1** or **Antenna 2** tab on the screen.

Define the obstruction zones by entering the pertaining angular points. Refer to the following example.

Obstruction Zone Setting - Example

An example for a simple obstruction zone setting is presented herein:

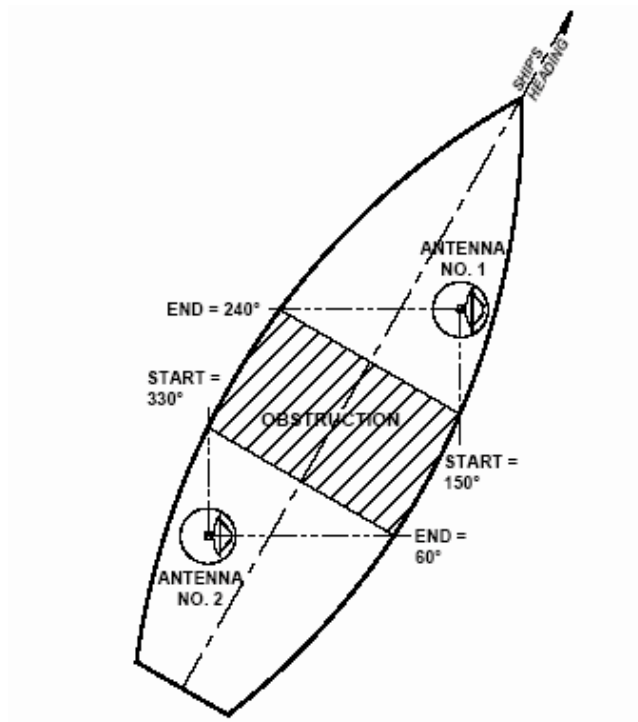

Figure 19 - Dual System - Layout Example

In the case above, Antenna 1 is blocked in the range of 90 degrees, starting from 150.0 to 240.0 degrees. Antenna 2 is also blocked in the range of 90 degrees, starting from 330.0 to 60.0 degrees (all angles are in Local Azimuth terms).

Note that the obstruction zone is defined by a “start” angle, which is always clockwise before an “end” angle.

According to the above example, the obstruction zone setting for both antennas will be as follows:

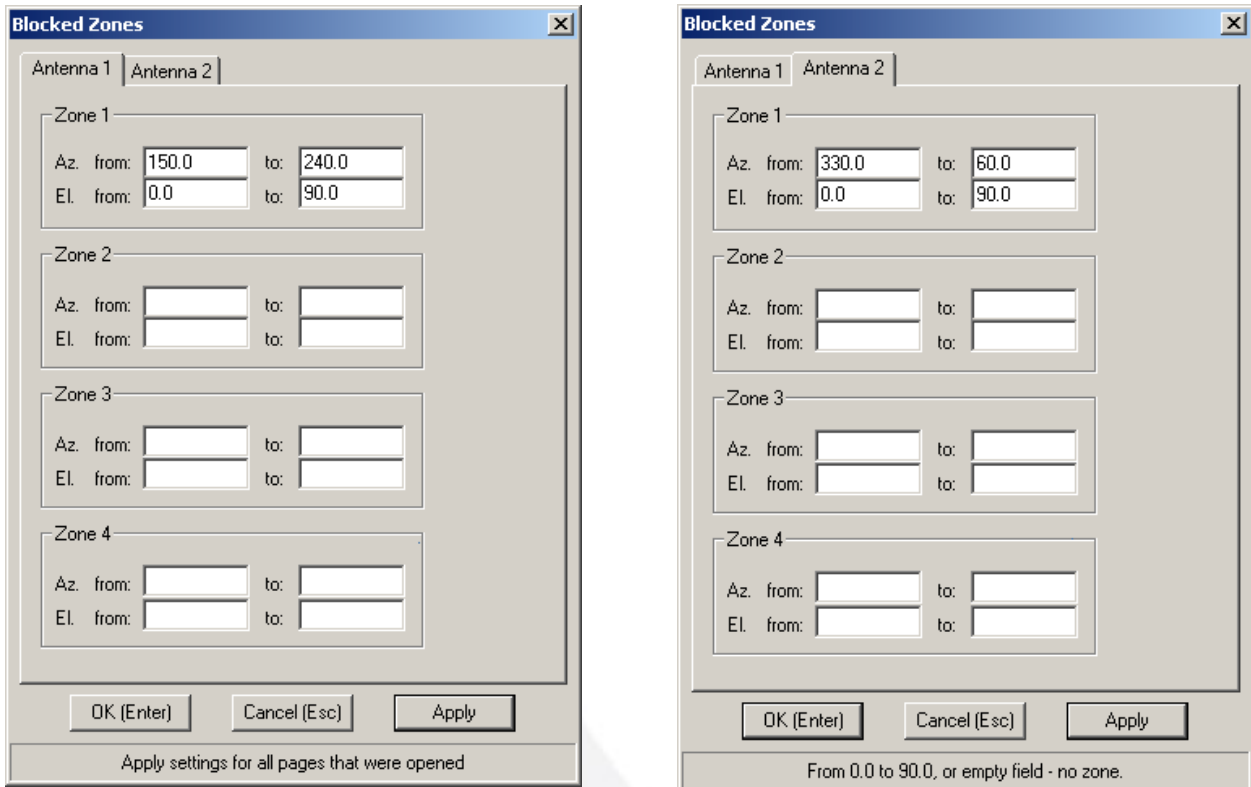

Figure 20 - Obstruction Zones Setting - Example

3.6.3 REMOTE BASIC OPERATION SCREENS

The CCU presents two Basic Operation Screens, for remote monitoring and operation of the systems.

Each Basic Operation Screens provides all controls and indications needed for normal basic operation of the system. This screen enables the operator to activate the basic modes of operation (satellite and channel selection), while monitoring system's parameters and indicators.

For more advanced control and configuration features, a series of password- accessible screens are available.

4 REMOTE DAOLINK APPLICATION

The Remote Dual System Operation (DaoLink) application enables to monitor the systems from a remote computer/laptop, which is connected to the CCU via LAN connection.

Invoke the application by clicking the **DaoLink** shortcut icon, located under **Start > Programs > Startup**.

The DaoLink application screen is displayed:

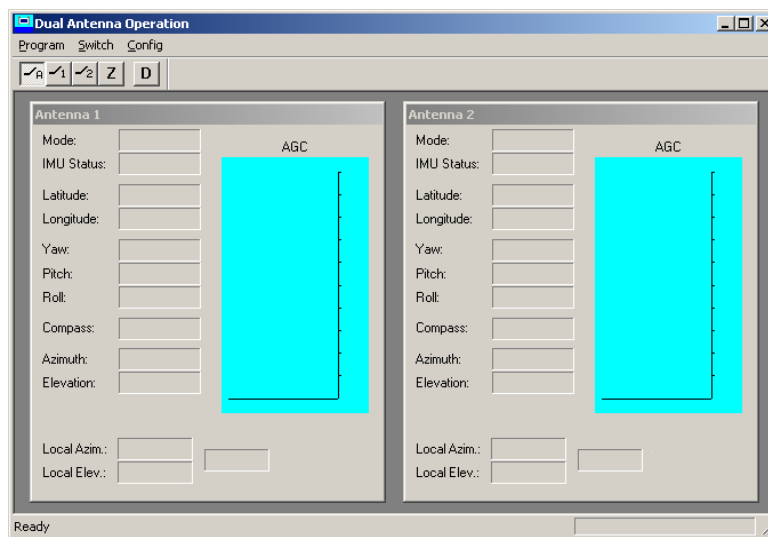

Select the **Config > Link** menu option.

The Link Configuration window is displayed:

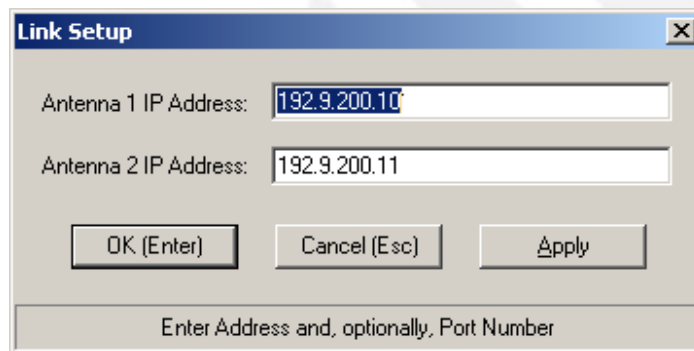

Verify that the proper IP addresses of both systems are entered into the **IP Address** fields. Then, the following screen is displayed, presenting the systems' status and data.

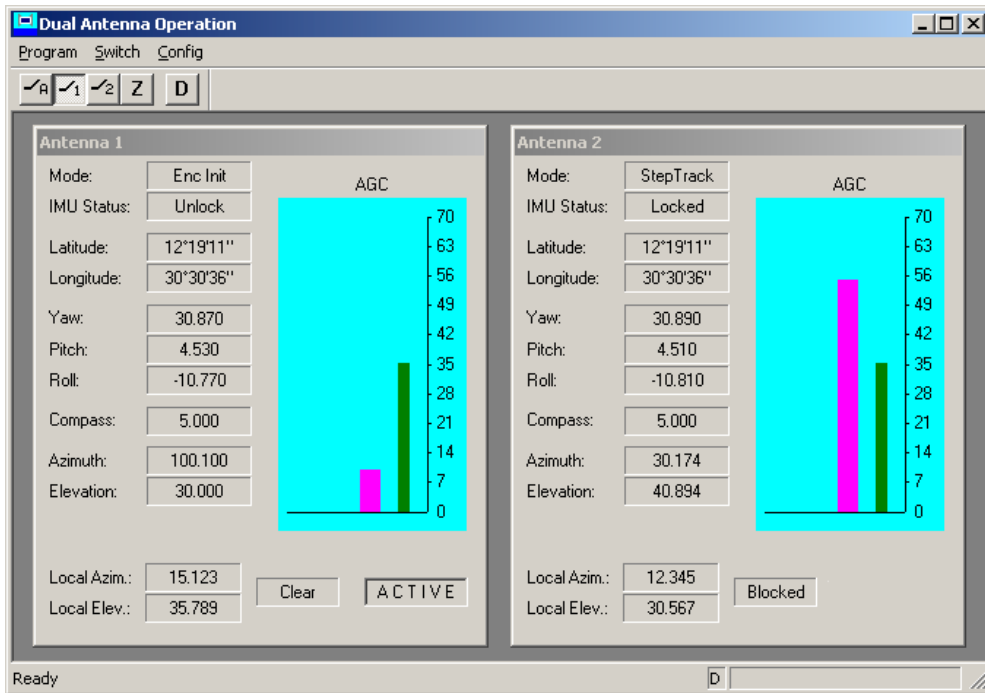

The Remote DaoLink application is identical to the local DaoLink application, excluding the use of the switch functions - the remote application is used for monitoring only and does not control the CCU switch.